

# BIM for Bridges and Structures Project Update

**T-19 Committee Meeting**

AASHTO Committee on Bridges and Structures Annual Meeting

Pittsburgh, PA

6/20/2022



**BIM** FOR  
BRIDGES  
AND STRUCTURES  
TPF-5(372)

# Agenda

1. MVD Update
2. Website Update
3. ROI Study
4. Unit Test Suite Update
5. Announcements and Q&A

# MVD Update

# General update:

International MVD development, dependency on IFC 4.3 and base MVDs

- **IFC4.3 has been completed** and submitted to ISO. Final release is planned for spring 2023.
  - Project team is using the “production” standard.
  - No technical changes are expected.
- Preparations have started for certification of **the Alignment-based Reference View (ARV) MVD**.
  - TPF-5(372) Bridge Design-to-Construction MVD will be an extension of the ARV MVD.
  - Project team is coordinating with bSI to share relevant test cases for certification.

# What is the data dictionary?

What is the difference between an MVD and a data dictionary?

## MVD

- Ability of software to support exchanges
- Required for software certification
- Exchange requirements to include alignment, geometry, relationships
- **Example:** Software shall support vertical and horizontal alignment plus superelevation to generate 3D extrusions in IFC-Export

## Data Dictionary

- Harmonized definitions of alphanumeric content
- Mapping of user language to IFC-definitions
- Includes properties, property groups and their assignment to model components
- **Example:** All bridge bearings (mapped to *IfcBearing*) shall contain properties about size, material, and degrees of freedom in IFC-Export

# MVD vs. Data Dictionary

## MVD

Provides ability to share the data



Software vendors/  
developers

IFC export  
option in  
software



Bridge Engineer

## Data Dictionary

Provides possible content of the  
data and its unique definitions



Automation Engineer/  
DOT CAD Manager

Apply data  
templates to  
CAD workspace

Create object  
libraries

# Timeline of the MVD Work

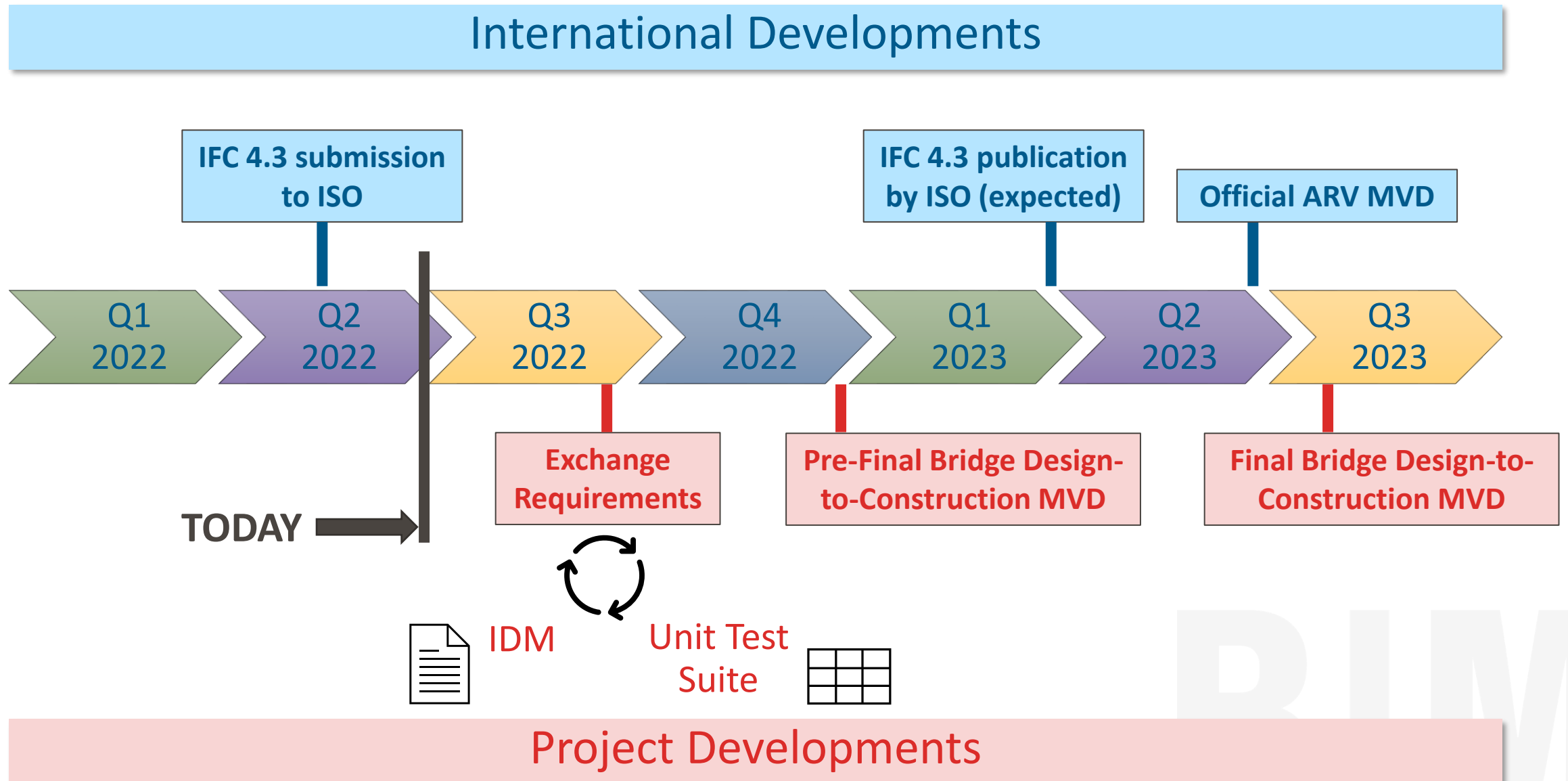

# Website Update



# BIM for Bridges Website

- The landing page has been updated to include a section for upcoming events
  - <https://BIMforBridgesUS.com>
- Two pages have been added
  - Calendar – expansion of the upcoming events on the landing page
  - Resources – documents and presentations produced and delivered from the project as well as links to BIM-related websites

# BIM for Bridges Website

**BIM** FOR BRIDGES AND STRUCTURES TPF-5(372)

CALENDAR RESOURCES

**Learn More**

BIM for Bridges and Structures

Advancing U.S national standards

**UPCOMING EVENTS**

- NIBS BIM Council**  
Wednesday, June 1  
Wednesday, June 1  
[View details →](#)
- Annual buildingSMART USA Open Standards Conference**  
Tuesday, June 14  
Thursday, June 16  
[View details →](#)
- AASHTO Committee on Bridges and Structures Annual Meeting**  
Monday, June 20  
Thursday, June 23  
[View details →](#)
- JTCEES Webinar Series: Digital Construction State DOT Perspective**  
Monday, June 20  
Monday, June 20  
[View details →](#)

# BIM for Bridges Website

## Calendar

**NIBS BIM Council**  
Wednesday, June 1  
Wednesday, June 1  
[View details --](#)

**Annual buildingSMART USA Open Standards Conference**  
Tuesday, June 14  
Thursday, June 16  
[View details --](#)

**AASHTO Committee on Bridges and Structures Annual Meeting**  
Monday, June 20  
Thursday, June 23  
[View details --](#)

**JTCEES Webinar Series: Digital Construction State DOT Perspective**  
Monday, June 20  
Monday, June 20  
[View details --](#)

June 2022

| Sun  | Mon | Tue  | Wed                   | Thu | Fri | Sat |
|--|-----|--|-----------------------|-----|-----|-----|
| 29   | 30  | 31   | 1<br>NIBS BIM Council | 2   | 3   | 4   |
| 5  | 6   | 7  | 8                     | 9   | 10  | 11  |
| 12   | 13  | 14<br>Annual buildingSMART USA Open Standards Conference | 15                    | 16  | 17  | 18  |
| 19<br>AASHTO Committee on Bridges and Structures Annual Meeting<br>JTCEES Webinar Series: Digital Construction State DOT Perspective | 20  | 21   | 22                    | 23  | 24  | 25  |
| 26   | 27  | 28   | 29                    | 30  | 1   | 2   |

## Resources

### DOCUMENTS

**Report**  
Investigation and Exploration Task 1 Report

**Plan**  
Software Vendor Engagement Plan

**Memo**  
Terminology Database

### PRESENTATIONS

- TPF-5(372) BIM for Bridges and Structures Information Delivery Manual *December 1, 2021*
- Pooled Fund Initiative AASHTO Committee on Bridges and Structures Annual Meeting, T19 Committee Meeting *July 13, 2021*
- TPF 5(372) Annual Software Vendor Workshop *Day 1 Tuesday, 20 July 2021*
- TPF 5(372) Annual Software Vendor Workshop *Day 2 Wednesday, 21 July 2021*
- TPF 5(372) Annual Software Vendor Workshop *Day 3 Thursday, 22 July 2021*

### LINKS

**FHWA BIM for Infrastructure**  
[Visit Site](#)

**buildingSMART USA**  
[Visit Site](#)

**Highway Engineering Exchange Program**  
[Visit Site](#)

**U.S. National BIM Program (NIBS)**  
[Visit Site](#)

**AASHTO Committee on Bridges and Structures**  
[Visit Site](#)

**BuildingSMART International**  
[Visit Site](#)

# ROI Study

Revised Scope and Schedule for Contract Year 4

# Objectives

- Describe the benefits and costs of using BIM for bridges
- Describe the additional benefits and costs of using the IFC standard
- Provide an overview of existing tools for quantifying the ROI of BIM
  - Focus on TFRS-02 Tool (Lifecycle BIM for Infrastructure)
  - Identify areas for improvement, particularly to focus on bridges
- Determine data collection needs for use of existing tools in future ROI assessments of BIM for bridges
- Address common methodological issues for quantifying the ROI of BIM for bridges

# Key Activities & Assumptions

- Activities

- 1) Synthesis of Literature Review (started in Year 3)
- 2) Qualitative Assessment of Benefits and Costs
- 3) Overview of Existing Tools and Identification of Data Needs
- 4) Investigation of ROI Methodological Issues (Q&A format)

- Assumptions

- 1) No primary data collection (use of literature findings & interviews)
- 2) Not a formal benefit-cost analysis (no ROI estimate)
- 3) Focus on existing resources and data collection needs
- 4) All findings summarized in White Paper

# Deliverables

- One 20 to 30 page-long White Paper
  - Introduction (context, objectives)
  - Qualitative assessment of benefits and costs
  - Existing tools and data collection needs
  - Methodological issues / questions & answers
  - Conclusion
- 2 to 3-page Executive Summary, with visuals
- Options for publishing and/or presenting paper at conference (e.g., 2024 TRB Annual Meeting)

# Expected Timeline of ROI Study

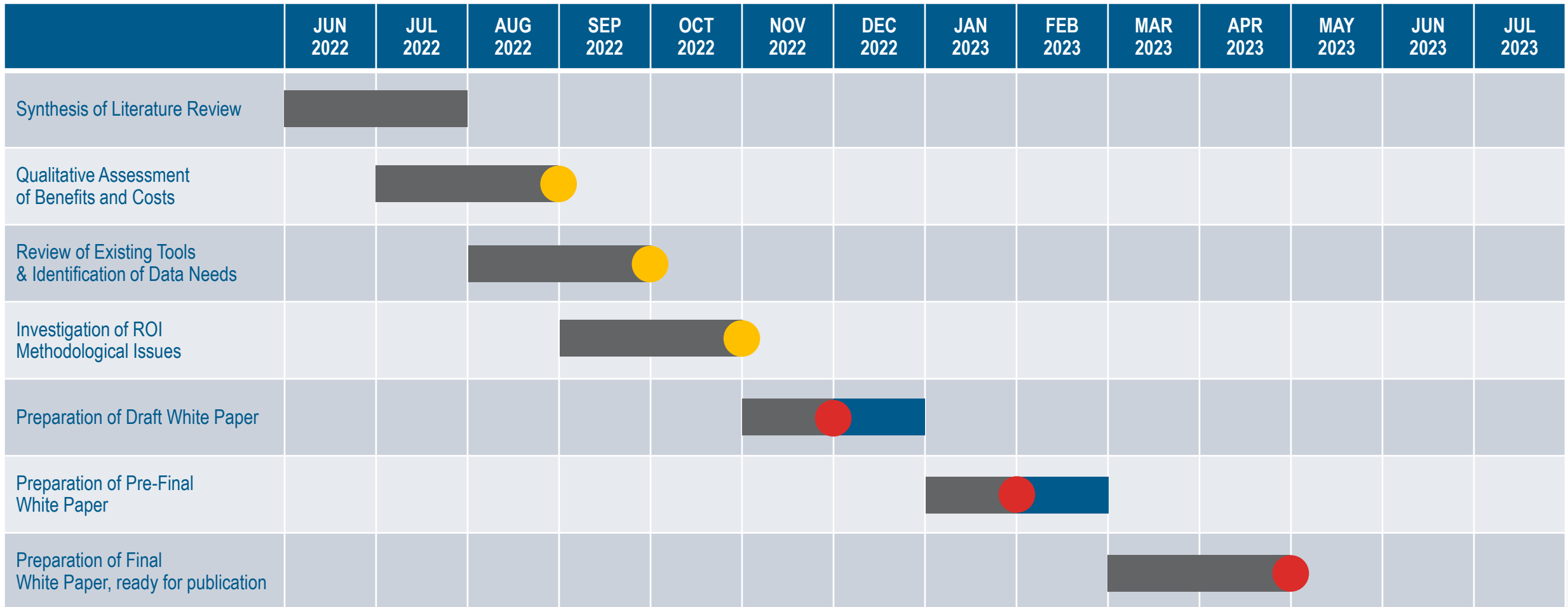



# Unit Test Suite Update

# Unit Test Suite

Instructions for modeling bridge elements and designs to enable software developer/vendor implementation testing and validation of IFC-based exchange requirements.

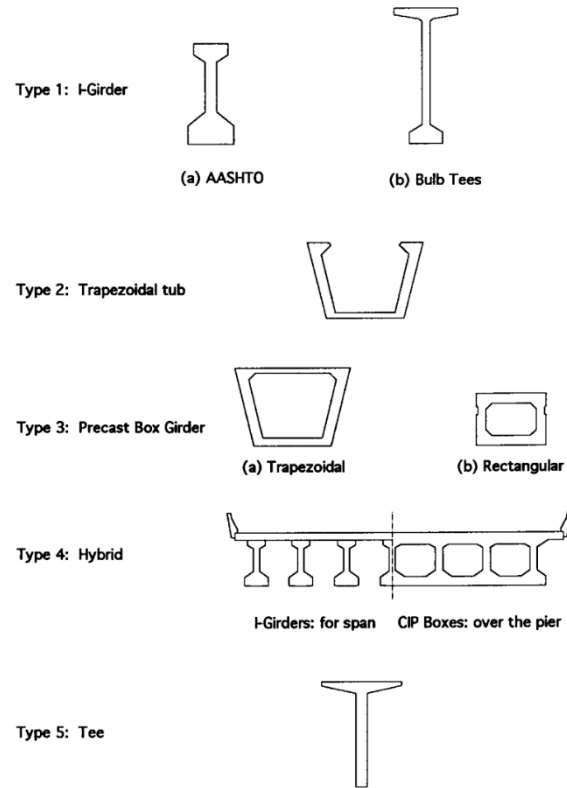
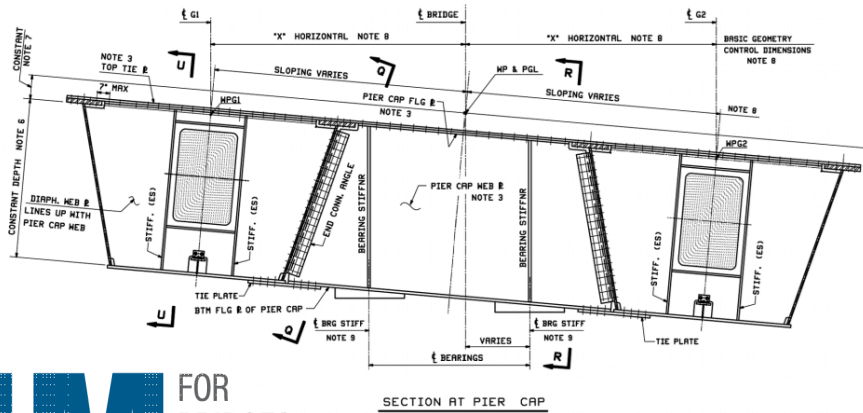
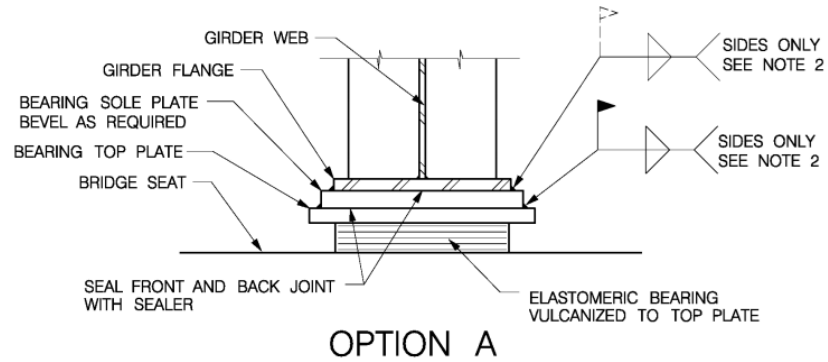
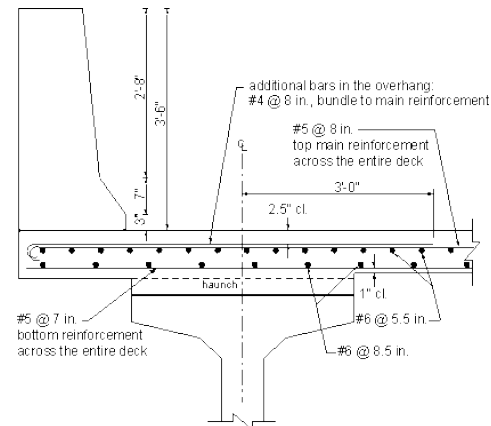

FIGURE 4. Common cross section shapes used in spliced girder bridge applications.



## IFC4.3 Schema Properties

| Property Set | Property | Value    |
|--------------|----------|----------|
| Information  | Name     | Pier 01  |
| Information  | Type     | B        |
| Information  | Material | Concrete |

## Data Dictionary Properties

| Property Set | Property           | Value    |
|--------------|--------------------|----------|
| AASHTO Info  | Custom Property 01 | Value 01 |
| AASHTO Info  | Custom Property 02 | Value 02 |
| AASHTO Info  | Custom Property 03 | Value 03 |

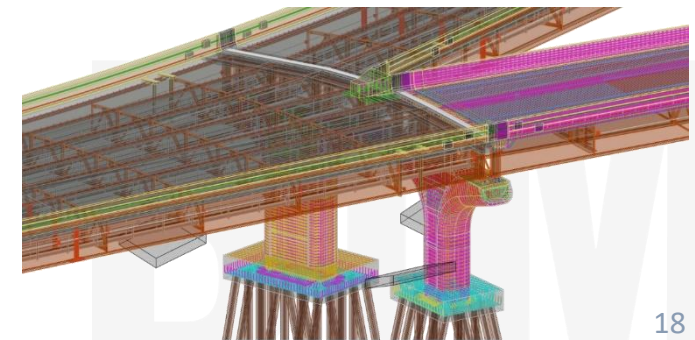
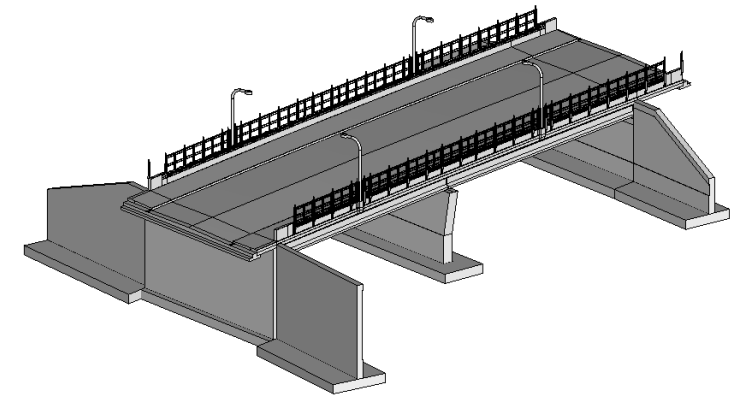

## Summary:

The Unit Test Suite is designed to provide software developers/vendors with a series of instructions to create and export models of various elements, systems, and conditions across the breadth of expected supported use cases. It uses the common software development methodology of reducing complex software to the most basic operational "unit" that can be objectively judged as to being correct or not. These unit tests start at simple, single elements and then aggregate in various configurations and growing size and complexity at each level. This enables the developer to quickly test the quality of IFC output and more easily troubleshoot basic issues before moving onto the next level of complexity. Ideally, by the time the developer reaches the level of a complete bridge design, there are few issues to correct and none are explicitly related to prior unit test cases.

The baseline "Level 1 - Elements" list is based on the "National Bridge Elements (NBEs)" and "Bridge Management Elements (BMEs)", as defined in the "Manual for Bridge Element Inspection, Second Edition, 2019" by AASHTO, including prestressed concrete-, reinforced concrete-, masonry-, and steel-based material configurations, as well as "Chapter 3 - Scope" of Part One: Industry Use Narrative of the "Information Delivery Manual (IDM): Construction Contract Model, Representing the Handoff from Design to Construction for Highway Bridges". All other lists are logical aggregations of the elements growing in complexity. The "IFC Concepts Tested" for each entry in each list is defined by the exchange requirements of the IDM and resulting Model View Definition (MVD).

## Exclusions:

The following elements, elements types, system types, and bridge designs are explicitly excluded from

- Timber-based elements and bridges
- Cable-stayed, or suspension, bridges
- Movable bridges
- Steel Truss bridges
- "Other" materials, unless explicitly noted

Agency-Defined NBEs and BMEs  
 - Independent Agency-Defined Elements

| Level   | Name         | Description  |  |
|---------|--------------|--|--|
| Level 1 | Elements     | Basic elements of bridge construction in relevant geometric permutations         |  |
| Level 2 | Arrays       | Simple arrays of similar basic elements  |  |
| Level 3 | Aggregations | Aggregation of elements and needed components superstructures subsets/bays/spans |  |
| Level 4 | Bridges      | Examples of complete supported bridge designs                                    | <ul style="list-style-type: none"> <li>- Levels 1, 2, &amp; 3, +...</li> <li>- IfcAlignment</li> <li>- Geolocation</li> <li>- Project hierarchy including Project, Site, Facility, ....</li> </ul> |

**Level 1 – Elements (69)**  
**Level 2 – Arrays (39)**  
**Level 3 – Aggregations (~20)**  
**Level 4 – Bridges (7)**  
  
**~135 tests identified so far**

## General Notes:

1. PSC = Prestressed Concrete (aka Precast), RC = Reinforced Concrete (aka Cast-in-Place)
2. All concrete-based elements should include reinforcing, conduits, electrical boxes, and embedded plates.
3. Any integral supports for appertanances not included in the scope (e.g., signs, lights) should be included.
4. The Level of Geometric Detail is based on previous construction documentation delivery standards.
5. Elements are modeled in their in situ, fully dead loaded state, no cambering is shown.

**Summary:**

The Unit Test Suite is designed to provide software developers/vendors with a series of instructions to create and export models of various elements, systems, and conditions across the breadth of expected supported use cases. It uses the common software development methodology of reducing complex software to the most basic operational "unit" that can be objectively judged as to being correct or not. These unit tests start at simple, single elements and then aggregate in various configurations and growing size and complexity at each level. This enables the developer to quickly test the quality of IFC output and more easily troubleshoot basic issues before moving onto the next level of complexity. Ideally, by the time the developer reaches the level of a complete bridge design, there are few issues to correct and none are explicitly related to prior unit test cases.

The baseline "Level 1 - Elements" list is based on the "National Bridge Elements (NBEs)" and "Bridge Management Elements (BMEs)", as defined in the "Manual for Bridge Element Inspection, Second Edition, 2019" by AASHTO, including prestressed concrete-, reinforced concrete-, masonry-, and steel-based material configurations, as well as "Chapter 3 - Scope" of Part One: Industry Use Narrative of the "Information Delivery Manual (IDM): Construction Contract Model, Representing the Handoff from Design to Construction for Highway Bridges". All other lists are logical aggregations of the elements growing in complexity. The "IFC Concepts Tested" for each entry in each list is defined by the exchange requirements of the IDM and resulting Model View Definition (MVD).

**Exclusions:**

The following elements, elements types, system types, and bridge designs are explicitly excluded from

- Timber-based elements and bridges
- Cable-stayed, or suspension, bridges
- Movable bridges
- Steel Truss bridges
- "Other" materials, unless explicitly noted

Agency-Defined NBEs and BMEs  
 - Independent Agency-Defined Elements

| Level   | Name         | Description  | IFC Concepts Tested  |
|---------|--------------|--|--|
| Level 1 | Elements     | Basic elements of bridge construction in relevant geometric permutations             |  |
| Level 2 | Arrays       | Simple arrays of similar basic elements  |  |
| Level 3 | Aggregations | Aggregation of elements and needed components for superstructures subsets/bays/spans | - IfcRelConnects   |
| Level 4 | Bridges      | Examples of complete supported bridge designs  | - Levels 1, 2, & 3, +...<br>- IfcAlignment<br>- Geolocation<br>- Project hierarchy including Project, Site, Facility, .... |

**Example**

Level 1 – Element: Cross-frame angle

Level 2 – Array: Cross-frame

Level 3 – Aggregation: Superstructure

Level 4 – Bridge

**General Notes:**

1. PSC = Prestressed Concrete (aka Precast), RC = Reinforced Concrete (aka Cast-in-Place)
2. All concrete-based elements should include reinforcing, conduits, electrical boxes, and embedded plates.
3. Any integral supports for appertanances not included in the scope (e.g., signs, lights) should be included.
4. The Level of Geometric Detail is based on previous construction documentation delivery standards.
5. Elements are modeled in their in situ, fully dead loaded state, no cambering is shown.



# Unit Test Suite: Update

## Scope

- 7 bridge designs identified
- Actual projects
- Additional Level 1 Element tests based on state standards

## Timeline for Vendors

- Level 1 outline completed beginning of May 2022
- Circulate ledger to Software Vendor Advisory Group in June for review
- Level 1 & 2 Unit Test instructions delivered to vendors at end of July, with MVD requirements
- Levels 3 & 4 and revisions by end of August



# Unit Test Suite: Review by T-19/Pooled Fund

## Suggested Review Process

- June 27 - Team to provide ledger w/ illustrations
- Week of July 11 - Orientation
- August 12 - Comments due

**Purpose of review is to make sure that we are covering all reasonable permutations for conventional workhorse bridge components.**



# Unit Test Ledger

## Level 1 – Bridge Model Elements (1/3)

| Element                                  | Permutation   | Test Name | File Name | Notes | Reference  |
|--|---|-----------|-----------|-------|--|
| Alignment                                | Curved horiz and vert   |           |           |       | 1_Iowa DOT_Johnson County I-80 I-380 Design 320_2018 |
|  | Straight horiz, curved vert (three span)                        |           |           |       | 2_Iowa Municipality_Shaver Road Bridge_06112021      |
| Approach Slab                            | RC  |           |           |       | 2_Iowa Municipality_Shaver Road Bridge_06112021      |
|  | RC Sleeper (Approach Slab support)                              |           |           |       | 2_Iowa Municipality_Shaver Road Bridge_06112021      |
| Deck                                     | PSC slabs/panels (1/2 depth) on Steel Girders                   |           |           |       | Deck PSC   |
|  | PSC slabs/panels (1/2 depth) on PSC girders                     |           |           |       | Deck PSC   |
|  | RC Slab on PSC Girder (straight along curved roadway alignment) |           |           |       | 3_Nebraska DOT_US275_Scribner North IT Girder Bridge |
|  | RC Slab on Steel Girder   |           |           |       | 1_Iowa DOT_Johnson County I-80 I-380 Design 320_2018 |
|  | RC Slab (solid slab, no girders)                                |           |           |       | 2_Iowa Municipality_Shaver Road Bridge_06112021      |
| Sidewalk w/ curb                         | RC Slab, raised sidewalk on deck                                |           |           |       | 2_Iowa Municipality_Shaver Road Bridge_06112021      |
| Deck Drains                              | Slotted Trench, no deck depression                              |           |           |       | 1_Iowa DOT_Johnson County I-80 I-380 Design 320_2018 |
|  | Point drain/tube w/ deck depression                             |           |           |       | 2_Iowa Municipality_Shaver Road Bridge_06112021      |
| Joints                                   | Strip Seal Expansion Joint                                      |           |           |       | 1_Iowa DOT_Johnson County I-80 I-380 Design 320_2018 |
|  | Modular Joint w/thickened deck slab                             |           |           |       | 1_Iowa DOT_Johnson County I-80 I-380 Design 320_2018 |
|  | Pourable Joint Seal (w/ backer rod)                             |           |           |       | Pourable Joint with Backer Rod                       |
|  | Compression Joint Seal  |           |           |       | Compression joint details                            |
|  | Tooth/Finger Joint  |           |           |       | 5_Iowa DOT_US34 over Missouri River_Design 311_2011  |
| Surfaces / Coatings / Protective Systems | Deck Wearing Surface (3" asphalt)                               |           |           |       | 3_Nebraska DOT_US275_Scribner North IT Girder Bridge |
| Bridge Rail / Barrier / Parapet          | RC, F-Shape Barrier   |           |           |       | 1_Iowa DOT_Johnson County I-80 I-380 Design 320_2018 |
|  | RC, Open Rail   |           |           |       | 3_Nebraska DOT_US275_Scribner North IT Girder Bridge |
|  | RC parapet w/ Metal Top Rail                                    |           |           |       | 2_Iowa Municipality_Shaver Road Bridge_06112021      |
|  | RC Sidewalk separation barrier                                  |           |           |       | 2_Iowa Municipality_Shaver Road Bridge_06112021      |
| Integral Supports for signs/lighting     | Steel   |           |           |       | 1_Iowa DOT_Johnson County I-80 I-380 Design 320_2018 |
|  | RC light pole blister on deck                                   |           |           |       | Light Pole Blister                                   |



# Unit Test Ledger

## Level 4 – Complete Bridges

| Bridge Type   | Test Name | File Name | Notes | Reference  |
|---|-----------|-----------|-------|--|
| Highway ramp, steel superstructure, non-standard concrete piers   |           |           |       | 1_Iowa DOT_Johnson County I-80 I-380 Design 320_2018 |
| Water crossing, concrete superstructure   |           |           |       | 2_Iowa Municipality_Shaver Road Bridge               |
| Water crossing, skewed layout, concrete superstructure  |           |           |       | 3_Nebraska DOT_US275_Scribner North IT Girder Bridge |
| Highway ramp, concrete superstructure, curved alignment   |           |           |       | 4_Polk, Ramp B over UPRR_Design                      |
| Water crossing, long span, mixed steel and concrete super structure, mixed standard and non-standard concrete piers |           |           |       | 5_Iowa DOT_US34 over Missouri River_Design           |
| Water crossing, simple span, concrete box girders   |           |           |       | 6_PennDOT_67343_5_Structure Plan                     |
| Box culvert   |           |           |       | 8_NC DOT_C0070-CLONTZ_LONG_ROAD-OVER-GRASSY_BRANCH   |



# Unit Test Suite & Certification

When complete, the Unit Test Suite will also serve as the test needed for Certification of an application's ability to export and/or import IFC models based on the MVD.

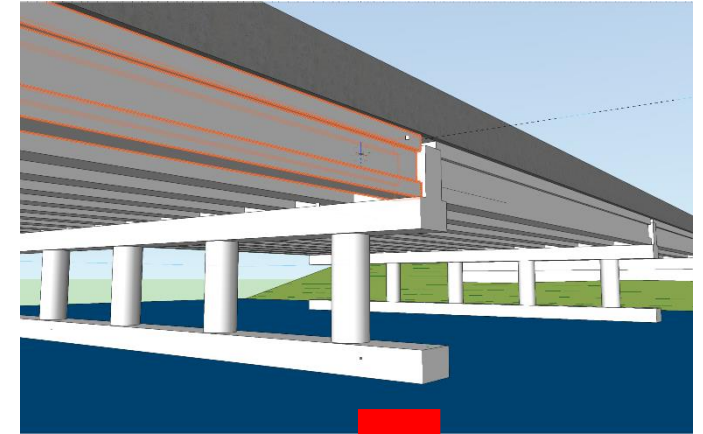

## EXPORT



## IMPORT

Based on MVD

Assumed design/modeling applications

Initially based on MVD, but broader IFC4.3 support is expected

Dependent on software purpose/functionality



IFC4.3  
(IFC-STP = .ifc)

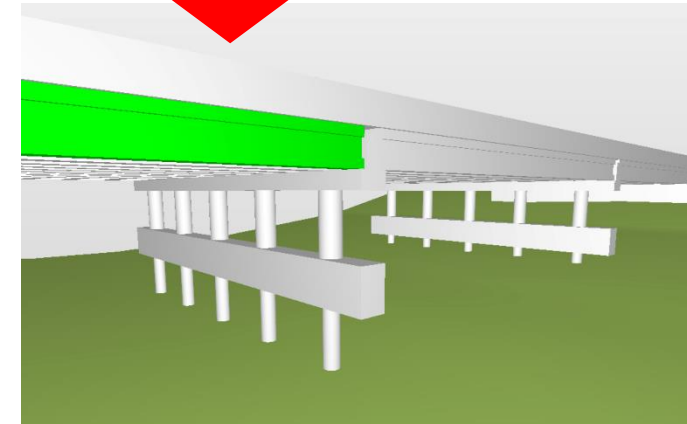

# Announcement #1

- Software Vendor Workshop
  - Wednesday (June 22), 8 AM to noon
  - Allegheny Room, 17<sup>th</sup> floor
- Open to all state DOTs and FHWA
- Agenda
  - 8:00 – Welcome and introductions
  - 8:15 – Update on bSI's IFC4.3 and ARV MVD, including Q&A
  - 8:45 – Update on TPF-5(372) MVD and Data Dictionary, including Q&A
  - 9:15 – Unit Test Suite Update
  - **9:45 – Coffee break and networking opportunity**
  - 10:30 – Design-to-Construction Workflows Deep Dive
  - 12:00 – Adjourn

# Announcement #2

- TPF-5(372) is approved for a sixth funding year.
- This will provide for a fifth contract year (February 2023-February 2024) of project work for the consultant team.
- Please confirm with your research funding contacts that funding is being earmarked in an upcoming work program.
  - Funding contacts should have received funding request emails.
- Please email Jim Hauber of Iowa DOT if you have questions - [James.Hauber@iowadot.us](mailto:James.Hauber@iowadot.us)

# Announcement #3

- Iowa DOT is organizing a 2<sup>nd</sup> BIM for Bridges and Structures Pooled Fund.
- Potential activities could include:
  - Training materials leveraging the outcomes of TPF-5(372)
  - Support for pilot projects implementing the standard from TPF-5(372)
  - Development of additional IDMs and MVDs, such as for Digital As-Builts and Asset Management
- Please email Jim Hauber of Iowa DOT if your state may be interested - [James.Hauber@iowadot.us](mailto:James.Hauber@iowadot.us)
- Official solicitation expected in early 2023.

# Questions?

**Julie Rivera, PE, SE**  
TPF-5(372) Project Manager, HDR  
Email: [julie.rivera@hdrinc.com](mailto:julie.rivera@hdrinc.com)



**BIM** FOR  
BRIDGES  
AND STRUCTURES  
TPF-5(372)